

# HAXIP Wall Mounted Axial Fan With Plastic Blades

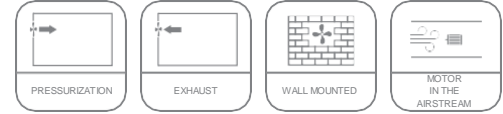

HAXIP fans can be easily mounted on the walls with its square body. Standard fan has grille guard and powder coating. Blades can be aluminum as clients request.



MOTOR INSULATION CLASS	F CLASS
MOTOR PROTECTION CLASS	IP 55
MOTOR EFFICIENCY CLASS	IE2-IE3
MOTOR ENCLOSURE TYPE	TEFC
MOTOR BRAND	GAMAK-VOLT-WATT
BODY MATERIAL	GALVANIZED SHEET METAL
BODY COATING	ELECTROSTATIC POWDER PAINT
IMPELLER MATERIAL	PLASTIC
DUTY CYCLE	IEC Duty Cycle-S1
WORKING AMBIENT TEMPERATURE	-20 - +50 °C
DIRECTIVE	IEC-60335-2-80, ISO 1940-1

MODEL	VOLTAGE (V)	FREQUENCY (Hz)	POWER (kW)	REVOLUTION (rpm)	FLOW RATE (m³/h)	NOISE LEVEL (dB(A))	PRICE
HAXIP 400-5-25	380	50	0,37	1.450	2.950	66	
HAXIP 450-5-25	380	50	0,55	1.456	4.250	69	
HAXIP 500-5-25	380	50	0,55	1.453	6.000	72	
HAXIP 560-5-25	380	50	0,75	1.466	8.200	75	
HAXIP 630-5-30	380	50	1,10	1.465	13.600	80	
HAXIP 710-5-30	380	50	1,50	1.472	19.400	83	
HAXIP 800-5-30	380	50	2,20	1.459	26.000	85	
HAXIP 800-5-35	380	50	3,00	1.463	31.500	89	
HAXIP 900-5-35	380	50	4,00	1.471	40.000	90	
HAXIP 900-5-40	380	50	5,50	1.472	45.500	93	
HAXIP 1000-5-40	380	50	7,50	1.478	55.000	94	

Values are for 0 Pa.

## DRAWING

### OPTIONS

- **Electro-Static Powder Coating**
- Custom Fans For Specific Flow Rate and Pressure
- **5, 8, 12, or 16 Blade Fan**
- **Aluminium or Plastic Blades**
- **System Automation**
- **Two-Speed Motor**

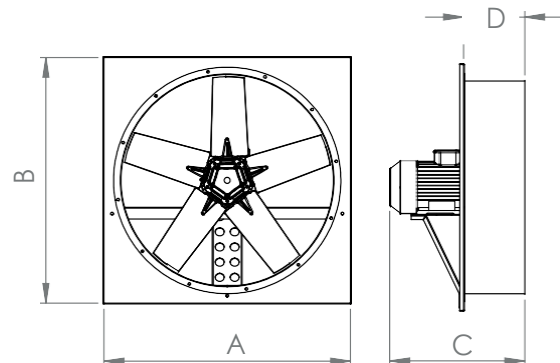

MODEL	A (mm)	B (mm)	C (mm)	D (mm)
HAXIP 400	570	570	400	200
HAXIP 450	610	610	410	200
HAXIP 500	650	650	410	200
HAXIP 560	680	680	410	200
HAXIP 630	750	750	420	200
HAXIP 710	830	830	450	200
HAXIP 800	920	920	480	200
HAXIP 900	1020	1020	590	300
HAXIP 1000	1120	1120	700	300

